

**FILED**  
**United States Court of Appeals**  
**Tenth Circuit**

**PUBLISH**

**UNITED STATES COURT OF APPEALS**  
**TENTH CIRCUIT**

**August 25, 2015**

**Elisabeth A. Shumaker**  
**Clerk of Court**

LARRY KIRKBRIDE,

Plaintiff - Appellee,

v.

TEREX USA, LLC, d/b/a Cedarapids,

Defendant - Appellant.

No. 14-4023

---

**APPEAL FROM THE UNITED STATES DISTRICT COURT**  
**FOR THE DISTRICT OF UTAH**  
**(D.C. No. 2:10-CV-00660-TC-EJF)**

---

Tracy H. Fowler, Snell & Wilmer LLP, Salt Lake City, Utah (Amber M. Mettler, Snell & Wilmer LLP, Salt Lake City, Utah, and Shannon Wells Stevenson, John M. Bowlin, Davis Graham & Stubbs LLP, Denver, Colorado, with him on the briefs), for Appellant.

Paul M. Simmons (Ralph L. Dewsnap, David R. Olsen, and Jessica A. Andrew, with him on the brief) of Dewsnap, King & Olsen, Salt Lake City, Utah, for Appellee.

---

Before **HARTZ**, **TYMKOVICH**, and **PHILLIPS**, Circuit Judges.

---

**HARTZ**, Circuit Judge.

---

Plaintiff Larry Kirkbride was injured while attempting to dislodge a foreign object from a portable rock-crushing plant manufactured by the predecessor of Defendant Terex USA, LLC. Kirkbride brought a products-liability action against Terex, and a jury found the company liable for failure to adequately warn of the plant's dangers, for defectively manufacturing a critical part inside the crushing plant that led to Kirkbride's injury, and for breaching an implied warranty of merchantability. Terex argues that Kirkbride failed to present sufficient admissible evidence to establish his three claims and that the jury was wrongly instructed on the implied-warranty claim. Exercising jurisdiction under 28 U.S.C. § 1291, we reverse and remand. Because there was insufficient evidence to hold Terex liable on any of the theories of recovery that went to the jury, Terex is entitled to judgment as a matter of law. Consequently, we need not consider other arguments presented by Terex.

## **I. BACKGROUND**

### **A. The Rock-Crushing Plant**

In 1980 Terex's predecessor manufactured and sold the portable rock-crushing plant at issue. As the name suggests, a rock-crushing plant is a large machine that crushes larger rocks into smaller ones. This particular plant was about the size of a large semitrailer and consisted of several components: a set of wheels, a chassis, a feeder system to carry material into the crusher, the crusher itself, a diesel engine to drive the crusher, and a conveyor to carry crushed material from the crusher.

Because a central issue in this case is whether the rock-crushing plant had a defective part—a “toggle plate”—that caused Kirkbride’s injury, we describe how the plant works. The process begins with material being loaded into a long, narrow feeder (about 20 feet long by 3.5 feet wide) that leads into the opening at the top of the crushing chamber. To prevent oversize rocks from clogging the chamber’s opening, the crushing plant when sold had a large metal bar called a crossmember before the opening to the crusher. Material that passes under the crossmember continues forward until it falls into the crushing chamber.

Reproduced below from the plant’s operation and maintenance (O&M) manual is a diagram of the crusher:

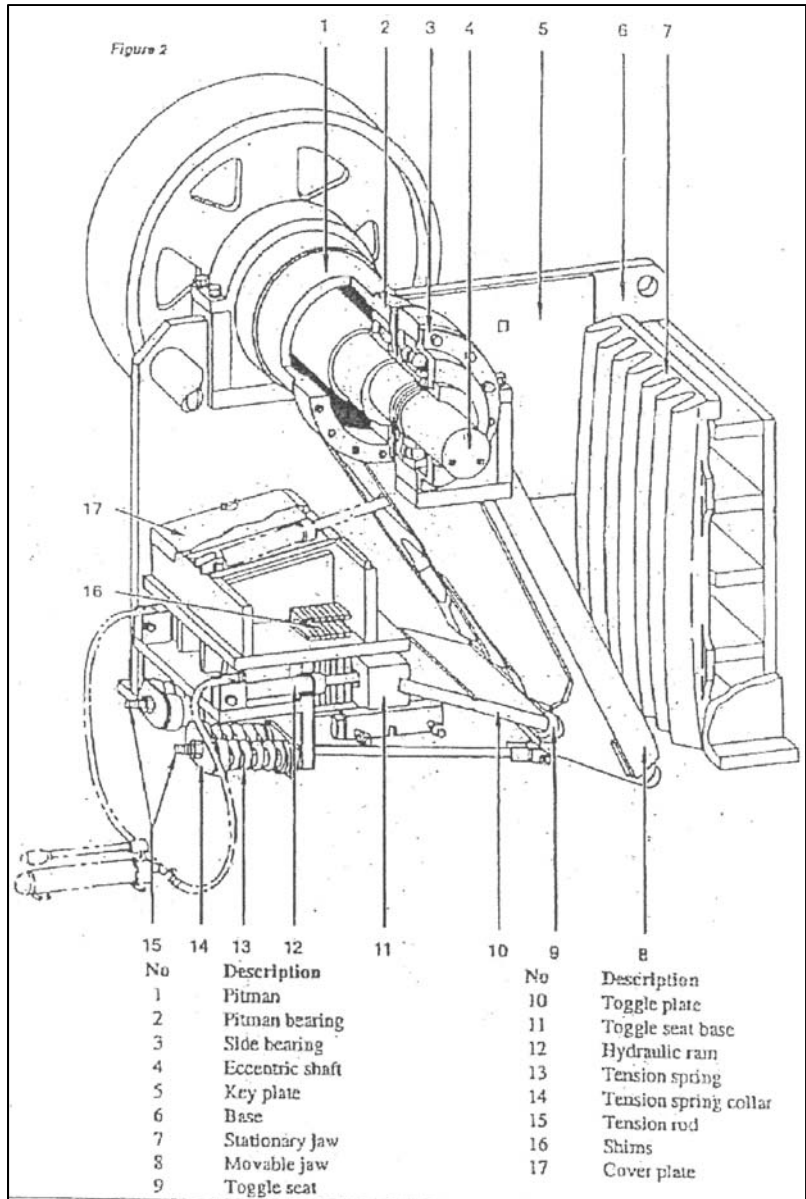

Aplt. App., Vol. 11 at 2389. When material enters the crushing chamber, it is crushed by two jaws, one stationary (labeled “7” in the diagram) and one movable (8). The top of the movable jaw, powered by the pitman (1), follows a circular path with a diameter of 1¼ inches, closer to and then farther from the stationary jaw. The cyclical compression

progressively breaks the material, allowing it to slip farther down the “V” between the jaws until it is small enough to fall through the gap at the chamber’s bottom.

The bottom of the movable jaw is connected to a rectangular metal plate called a toggle plate (10) and two tension rods (15), which pull the movable jaw toward the toggle plate and away from the stationary jaw. Besides keeping the bottom of the movable jaw in place, the toggle plate also functions as a protective device for workers and the jaw crusher itself. When uncrushable material (such as a large piece of metal) falls between the jaws, the jaws can jam and store energy as they exert pressure in an effort to crush the uncrushable material. As the pressure builds, the toggle plate acts as the “weakest link” and breaks before other, more expensive components (like the pitman) are damaged. *Id.*, Vol. 7 at 1621. When it breaks, there is nothing to hold the bottom of the movable jaw in place, so it swings open and the uncrushable material falls out. The danger to workers is that if the toggle plate does not break and a worker tries to dislodge the uncrushed material, the stored energy can cause the material to eject violently from the crushing chamber when it is released.

Terex’s manuals explain the purpose of the toggle plate and the dangers of stored energy caused by jaw-crusher jams. The O&M manual contains two statements. The first is: “The toggle plate is the oscillating link between the bottom of the pitman and the base toggle seat. It serves as a safety device in the crusher and will break when uncrushable material is encountered.” *Id.*, Vol. 11 at 2417. The second is: “The replaceable cast iron toggle plate also serves as a fuse or safety device in the crusher, as it

will break when uncrushable material such as a shovel tooth passes between the jaws.” *Id.* at 2391. And the safety manual contains the following warning for those occasions when material nevertheless gets stuck: “Use extreme caution when removing tramp iron from the crusher. Stored energy in jaw could cause serious bodily injury.” *Id.* at 2495. The written warning is accompanied by an illustration of a worker reaching down into the crushing chamber and being struck in the face by an ejected foreign object. That is what happened to Kirkbride.

### **B. The Accident and Aftermath**

After the rock-crushing plant was sold in 1980, it changed hands several times before being acquired in 1999 by Harper Sand and Gravel, Kirkbride’s employer. At some point before Kirkbride’s injury in August 2008 the plant’s crossmember was removed, and its warning placards may have been lost as well. Harper modified the plant by replacing its original diesel engine with an electric motor, reducing from 16 to 8 the number of v-belts transferring power from the motor to the flywheels, and replacing the feeder’s hydrostatic drive with an electric one. Harper requested from Terex a complete set of manuals for the plant; and in June 2008 (two months before Kirkbride’s injury) Harper ordered a new Terex toggle plate for the crushing plant and installed it within a few weeks.

On August 2, 2008, Harper employees were running the crushing plant when they noticed that a large boulder had become stuck in the crushing chamber, just above the jaws. They shut down the feeder and the jaw crusher and attempted, unsuccessfully, to

pull out the boulder with a chain pulled by a front-end loader. A supervisor noticed their efforts and called in Kirkbride, a front-end-loader operator, to help. The workers turned the crusher back on and attempted to break up the boulder by lowering a 19-inch metal “ripper tooth” on a chain into the jaws. The tooth broke off the chain and fell into the crushing chamber, wedging into the gap at the bottom and jamming the jaws. The v-belts driving the crusher began to smoke and squeal as the jaws futilely attempted to crush the tooth. The toggle plate did not break. The workers turned off the power and finally managed to remove the boulder by having Kirkbride pull it out with a chain attached to a track hoe. But the ripper tooth remained stuck.

Kirkbride brought an acetylene torch, climbed into the crusher, and began cutting the tooth. With a loud bang the tooth shot out of the jaws, striking Kirkbride’s neck and jaw as it flew 25 feet into the air.

A few days after Kirkbride’s injury the plant was put back into operation without changing the toggle plate then or at any time later while the plant remained in Harper’s control. Harper sold the plant in 2010, and it was inspected by the parties in July 2011. Critically, although Terex toggle plates for this kind of plant are designed to be just  $1\frac{7}{8}$  inches to 2 inches thick, the toggle plate found inside the plant was  $2\frac{3}{16}$  inches thick.

### **C. Procedural History**

Kirkbride sued Terex in Utah state court on theories of negligent manufacturing and design, negligence in providing inadequate warnings and instructions, strict products liability for manufacturing and design defects and for failure to warn, and for breach of

express and implied warranty. Terex removed the case to the United States District Court for the District of Utah on the basis of diversity jurisdiction. *See* 28 U.S.C. §§ 1332, 1441. Before trial, Kirkbride narrowed his claims to negligence, strict products liability (based on the alleged manufacturing defect in the toggle plate and the company’s allegedly inadequate warnings and instructions for resolving crusher jams), breach of express warranty (based on Terex’s statements in its manuals that the toggle plate “will break” when uncrushable material enters the jaws), and breach of the implied warranty of merchantability. *Aplt. App.*, Vol. 1 at 111–12 (internal quotation marks omitted). At trial, Terex unsuccessfully moved for judgment as a matter of law when Kirkbride rested his case. After the close of evidence, Kirkbride withdrew his express-warranty and negligence claims. The verdict form requested jury findings on the three remaining theories of liability. It asked (1) whether Terex failed to adequately warn users of the jaw crusher’s dangers and whether that was a cause of Kirkbride’s injury; (2) whether Terex manufactured the toggle plate that was in the crusher on the day of the accident, whether the toggle plate was defective, and whether the defect was a cause of Kirkbride’s injury; and (3) whether Terex breached an implied warranty of merchantability that the toggle plate was fit for its ordinary purpose and whether that was a cause of Kirkbride’s injury. The jury found Terex liable on all three theories and awarded Kirkbride damages of over \$3.5 million. Terex filed a renewed motion for judgment as a matter of law or for a new trial, which was denied.



## II. DISCUSSION

Terex argues that there was insufficient admissible evidence for the jury to find liability on any of Kirkbride's three theories, so the trial court erred in denying its motion for judgment as a matter of law. "Because this is a diversity case, we apply the substantive tort law of Utah" to Terex's challenges, *Brown v. Sears, Roebuck & Co.*, 328 F.3d 1274, 1278 (10th Cir. 2003), but we apply the federal-law standard for judgment as a matter of law, *see Jones v. United Parcel Serv., Inc.*, 674 F.3d 1187, 1195 (10th Cir. 2012). Under our standard, we review denial of the motion de novo, and Terex is entitled to judgment as a matter of law only "if the evidence points but one way and is susceptible to no reasonable inferences supporting the party opposing the motion." *Deters v. Equifax Credit Info. Servs., Inc.*, 202 F.3d 1262, 1268 (10th Cir. 2000) (internal quotation marks omitted). "[W]e will not weigh evidence, judge witness credibility, or challenge the factual conclusions of the jury," and will afford Terex the relief it seeks "only if there is no legally sufficient evidentiary basis" for Kirkbride's claims. *Id.* (internal quotation marks omitted); *see* Fed. R. Civ. P. 50(a)(1). Because the same damages are recoverable under each theory, Terex must prevail on all three theories of liability to obtain reversal of the judgment: "So long as the jury's verdict was supported by sufficient evidence under at least one valid theory of liability presented to the jury, we must affirm." *United States ex. rel. Absher v. Momence Meadows Nursing Ctr., Inc.*, 764 F.3d 699, 709 (7th Cir. 2014).

**A. Failure to Warn**

We first review the challenge to the jury's finding that Terex was liable for failure to warn adequately of the jaw crusher's dangers. Under Utah law, "a manufacturer who sells a product in a defective condition unreasonably dangerous to the user is strictly liable for any physical harm caused by the defect notwithstanding the fact that the manufacturer has exercised all possible care in the preparation and sale of his product." *House v. Armour of Am., Inc. (House I)*, 886 P.2d 542, 547 (Utah Ct. App. 1994) (internal quotation marks omitted). One such defect is an "inadequate warning regarding a product's use[, which] may render that product unreasonably dangerous." *Id.* But "[b]efore a manufacturer may be held liable for a failure to warn, that failure must be both the cause-in-fact and the proximate cause of the user's injury." *Id.* at 551.

Kirkbride argues that the warning was inadequate because it was not accompanied by an instruction on how to remove uncrushable material from the crusher (although he has not suggested what the instruction should have said). We need not decide the adequacy of the warning, however, because there was no evidence that a better warning would have prevented Kirkbride's injury. The Utah Supreme Court has said, "[I]f the event which produced the injury would have occurred regardless of the defendant's conduct, then the failure to provide a warning is not the proximate cause of the harm and the plaintiff's claim must fail." *House v. Armour of Am., Inc. (House II)*, 929 P.2d 340, 346 (Utah 1996) (internal quotation marks omitted). That is the case here.

As mentioned earlier in this opinion, Terex's safety manual warned workers to avoid doing exactly what Kirkbride did by exposing his head to metal stuck in the jaws:

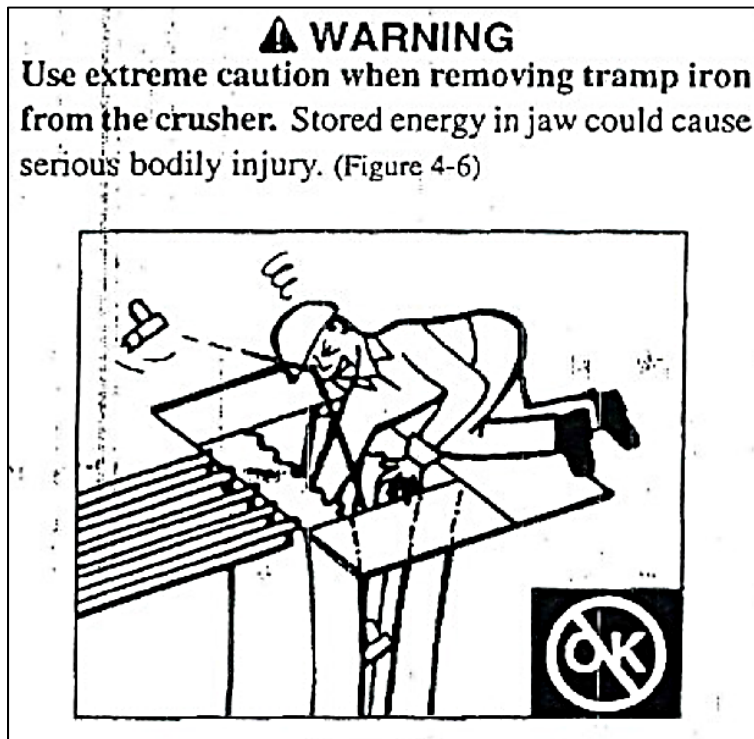

Aplt. App., Vol. 11 at 2495. But Kirkbride read neither the crushing plant's safety manual nor the (O&M) manual. Indeed, when asked if he had even read the manual for the front-end loader, he replied, "Why would you read a manual?" *Id.*, Vol. 6 at 1242.

Kirkbride asserts, however, that it was established at trial that Harper's maintenance people would refer to the manuals when performing repairs, and the manuals were supposed to be part of the training for workers assigned to operate the crushing plant. Therefore, he argues, "[t]he jury reasonably inferred from this evidence that, had Terex provided adequate instructions and warnings for what to do when [a jam occurs], the Harper employees working on the crusher would have been trained in those

procedures, Mr. Kirkbride would have followed the instructions, and he would not have been injured.” Aplee. Br. at 57–58.

This assertion and argument finds no support in the record. There were four workers on the scene at the time of the accident: Kirk Fetzer, Loren Slaymaker, Barry Gloster, and Marcos Vallartes. Fetzer and Slaymaker testified at trial, Gloster testified by deposition, and Vallartes could not be located. There is no evidence that any of them read the warning that *was* given. Indeed, the evidence shows that none of those present had even been trained on clearing a crusher jam by anyone who had read the manuals. Fetzer said that his only training on how to remove jams came from Vallartes. And despite Terex’s probing of many witnesses, none could say that Vallartes had ever been trained on the crushing plant or had read its manuals. Slaymaker testified that his only training with Harper consisted of an eight-hour classroom course sponsored by the Mine Safety and Health Administration and that he had received no training on crushers. Gloster testified that he was never trained on how to fix crusher jams until after the accident. Fetzer, Slaymaker, and Gloster all denied ever reading or being instructed to read any portion of the crushing plant’s manuals before the accident. And there is no evidence that anyone present told Kirkbride that he should be very cautious while removing uncrushable material from a jam, including by—at the very least—keeping his head clear (a warning that *was* in the manual). *Cf. Gen. Motors Corp. v. Saenz ex rel. Saenz*, 873 S.W.2d 353, 359 (Tex. 1993) (“If despite the inadequacy of [the manufacturer’s] instructions, following them would have prevented the accident, then

their inadequacy could not have caused the accident.”). It would be pure speculation to assume that the instruction (of unknown content) now demanded by Kirkbride would have been heeded.

Kirkbride protests that he proved causation with the help of a “heeding presumption.” Aplee. Br. at 58. According to this doctrine, adopted in Utah and many other jurisdictions, “in cases in which it cannot be demonstrated what the plaintiff would have done had he or she been adequately warned, the plaintiff should be afforded a rebuttable presumption that he or she would have followed an adequate warning had one been provided.” *House II*, 929 P.2d at 347 (internal quotation marks omitted). Under Utah law this presumption must be rebutted by a preponderance of the evidence. *See* Utah R. Evid. 301; *Barron v. Labor Comm’n*, 274 P.3d 1016, 1020 n.3 (Utah Ct. App. 2012).

There may be some question about the scope of the presumption, but at trial Kirkbride relied on it in the following form: “You can presume that if Terex had provided an adequate warning, Mr. Kirkbride would have read and followed it unless the evidence shows that Mr. Kirkbride would not have read or followed such a warning.” Aplt. App., Vol. 1 at 159 (Jury Instruction No. 22). Terex conclusively rebutted the presumption. Not only had Kirkbride not read the warning that *was* in the manual but he expressed a negative view of manuals. *See id.*, Vol. 6 at 1242 (“Why would you read a manual?”).

Thus, the element of causation necessary for Kirkbride's claim rests entirely on speculation. But "[t]o support a jury verdict, evidence must be based on more than mere speculation, conjecture, or surmise." *Rice v. United States*, 166 F.3d 1088, 1092 (10th Cir. 1999). We must vacate the jury's verdict on the failure-to-warn claim.

**B. Manufacturing Defect**

Next we address Kirkbride's manufacturing-defect claim. To succeed on such a claim, a plaintiff must prove that (1) the manufacturing defect made the product unreasonably dangerous, (2) the defect was present at the time of the product's sale, and (3) the defect caused the plaintiff's injury. *See Schaerr v. Stewart's Plaza Pharmacy, Inc.*, 79 P.3d 922, 928 (Utah 2003).

Kirkbride's theory centered on the crushing plant's toggle plate. As described earlier, the toggle plate is a relatively thin metal plate connected to the bottom of the movable crushing jaw. When the jaw encounters uncrushable material, it is the toggle plate's job to break, both for safety and to prevent a pressure buildup that causes something more valuable to break instead. Doubtless a thicker plate is harder to break. And the toggle plate found in the plant in July 2011 (about three years after the accident) was 3/16ths of an inch thicker than Terex's design specification. Had the toggle plate been manufactured properly, Kirkbride said in his opening statement to the jury, it would have broken as designed, the jaw would have swung open, and the ripper tooth would have fallen safely through, averting his injury.

Terex argues that Kirkbride's theory suffers from three fatal flaws: (1) the only evidence establishing that the defective toggle plate was manufactured by Terex came from inadmissible and insufficient expert testimony; (2) there was no evidence that the thickness of the plate rendered the crusher unreasonably dangerous; and (3) there was no evidence that the defect—the extra thickness—was the cause of the plate's failure to break. Because Terex prevails on (3), we need not address (1) or (2).

The alleged manufacturing defect is that the toggle plate was thicker than the design specifications. Kirkbride alleges that this defect caused the plate not to break. An essential element of his proof of causation therefore must be that a properly manufactured plate would have broken in the circumstances of the August 2008 accident. Consider an example. Suppose that a 2-inch plate breaks if subjected to 1000 pounds of force and a  $2\frac{3}{16}$ -inch plate breaks if subjected to 1200 pounds of force, but the force on the plate the day of the accident was only 900 pounds. Although a defective plate is harder to break, the force would be insufficient to break either one, so the defect would not be a cause of the jam. It is not obvious that a properly manufactured plate would always prevent a jam. After all, if the plate broke too easily, operations could be interrupted too often. (No Harper employee testified that he had ever seen a toggle plate break when the Terex crusher (or any other crusher) had jammed, even though all were familiar with jams and several had worked with crushers for years.) And the safety-manual warning about jammed tramp iron implies that the plate would not always break.

We agree with Terex that there was inadequate (nonexistent) proof that a nondefective plate would have broken. Kirkbride’s expert witness, Benjamin Railsback, was the only witness who discussed causation. Railsback, however, never analyzed whether a properly manufactured plate would have broken during the circumstances of Kirkbride’s accident. Rather, he simply testified, without calculations, testing, or other application of scientific methodology, that a thicker plate is—obviously—more difficult to break than a thinner one. When confronted on cross-examination with the fact that he had not run any tests to determine whether a defective plate would break, he replied, “That’s true, I don’t know whether it would break or not. I don’t need to do any testing as a mechanical engineer to know that something that’s too thick is more difficult to break.” *Aplt. App.*, Vol. 5 at 1073. But when next asked whether he had tested if a nondefective, two-inch plate would have broken, he replied, “No, sir.” *Id.*

We can find no statement in Railsback’s testimony regarding when a properly manufactured plate would break. This was no mere oversight. It is clear from the record that he had no opinion on the matter. Railsback’s only statement in which he compared a defective plate to a nondefective plate came on direct examination, when he opined that even a properly manufactured plate may not have broken (depending on the design):

[Kirkbride’s attorney]: Why didn’t the toggle plate break?

[Terex’s attorney]: Objection, Your Honor, foundation.

THE COURT: Well in his—in your opinion. Go ahead.

[Railsback]: In my opinion, the two primary reasons why the toggle plate didn’t break, the first reason is that it was too thick. This toggle plate was manufactured with a thickness of two and three-sixteenths of an inch, not the required dimension of two inches that is in the design drawings. *The*



*second reason might be that the toggle plate could have been over engineered or too thick to begin with. That dimension of two inches may be too thick even for normal operation, proper operation of this machine.*

THE COURT: Yes.

[Terex's attorney]: Move to strike. It is speculative.

THE COURT: Yeah, sustained.

*Id.* at 1015–16 (emphasis added). As indicated, that testimony was stricken by the district court. (The parties disagree on whether the district court struck the entirety of Railsback's answer, or just the second part. But that makes no difference because Kirkbride had the burden of proving causation and that required—at a minimum—ruling out the possibility that a nondefective plate would have remained intact, which he did not do.) What is important, however, is that the emphasized testimony removes any ambiguity about the absence of causation testimony—it is undisputable that Railsback had no opinion (and certainly, in the absence of testing or calculations, had no basis for an opinion) about whether a properly manufactured plate would have broken.<sup>1</sup>

Without expert testimony that a nondefective plate would have broken, the jury could only speculate that the manufacturing defect was the cause of the plate's failure to break. This it was not permitted to do. *See Truck Ins. Exch. v. MagneTek, Inc.*, 360 F.3d 1206, 1215–16 (10th Cir. 2004) (jury finding of causation cannot be based on speculation); *Burns v. Cannondale Bicycle Co.*, 876 P.2d 415, 418 (Utah Ct. App. 1994)

---

<sup>1</sup> We need not consider Terex's argument that Railsback was required to conduct testing on the breaking point of toggle plates for his theory to be reliable. It is not the lack of testing that concerns us, but Railsback's failure to rule out (whether by testing or other means) that a nondefective plate would have also remained intact despite the jam.

(a plaintiff must show that his injuries “proximately resulted from the product’s failure of performance *causally related* to its defective condition” (emphasis added) (internal quotation marks omitted)).

Our decision in *Bitler v. A.O. Smith Corp.*, 400 F.3d 1227 (10th Cir. 2004), cited by Kirkbride, is not to the contrary. The issue in *Bitler* was the admissibility of expert testimony, not the sufficiency of the evidence of causation. Here, we have assumed that Railsback’s unstricken testimony was properly admitted.

### **C. Implied Warranty**

Finally, Kirkbride contends that his judgment can be affirmed on his theory of implied warranty. Kirkbride brought a tort claim asserting that he was injured because Terex breached the implied warranty of merchantability when it sold the toggle plate. But the tort claim for breach of implied warranty has largely been subsumed into the doctrine of strict products liability. Terex contends that such is the law in Utah, so that once Kirkbride’s products-liability claims fail—the claim for design defect was abandoned before trial and we have found that there is insufficient evidence to support the claims for inadequate warnings and manufacturing defect—there is no need to address the implied-warranty claim. We agree.

We rely primarily on the Utah Supreme Court’s opinion in *Ernest W. Hahn, Inc. v. Armco Steel Co.*, 601 P.2d 152 (Utah 1979). In that case the plaintiff had brought claims for both strict products liability and breach of implied warranty. *See id.* at 155. The court summarized the history of the doctrine of strict products liability, noting how

liability for negligence had been extended by the use of warranty doctrine but that limitations in that doctrine led to the birth of the doctrine of strict products liability. *See id.* at 156–57. It then adopted the strict-products-liability doctrine as set forth in the Restatement (Second) of Torts § 402A. *Id.* at 158. The court devoted little attention to the plaintiff’s implied-warranty claim. It found it necessary to say only that “[t]he elements of both actions [implied warranty and strict products liability] are essentially the same,” so that the same defenses are available to both. *Id.* at 159 (footnote omitted).

There may be some ambiguity in the language “essentially the same,” leaving room for the possibility of differences in the elements of the two tort causes of action. But the historical summary in *Hahn* would suggest that if there were any differences, it would be that a warranty claim would be more limited than a strict-products-liability claim. And later Utah appellate opinions have read *Hahn* as support for the proposition that once a claim for strict products liability has been rejected, nothing is added by considering an implied-warranty claim. In *Burns*, 876 P.2d at 416, the Utah Court of Appeals addressed a personal-injury claim alleging defective bicycle brakes. The court affirmed a summary judgment in favor of the defendant. *See id.* Citing *Hahn*, the court wrote, “Insofar as Burns’s claim for breach of the implied warranty of merchantability is concerned, no separate analysis is required since it is essentially the same as a products liability claim.” *Id.* at 418 n.2. Five years later, the Utah Supreme Court adopted the same approach in affirming a summary judgment in *Straub v. Fisher & Paykel Health Care*, 990 P.2d 384 (Utah 1999). It said: “Straub provides no analysis for her breach of

implied warranty claim. We can only assume that she is not appealing this issue. In any event, the elements of strict liability and breach of warranty ‘are essentially the same.’” *Id.* at 389 n.1 (quoting *Hahn*, 601 P.2d at 159); *see also Davidson Lumber Sales, Inc. v. Bonneville Inv., Inc.* 794 P.2d 11, 14 (Utah 1990) (“The term ‘warranty’ has also been used, however, in tort law to have a meaning that is synonymous with strict liability.”).

Kirkbride cites *Utah Local Government Trust (ULGT) v. Wheeler Machinery Co.*, 199 P.3d 949, 955 (Utah 2008), for the proposition that the Utah Supreme Court has “cautioned against merging the two claims [strict products liability and breach of the implied warranty of merchantability].” Aplee. Br. at 60. That is not how we read the opinion. What the court did not want merged were contract and tort causes of action, even if both might be labeled as breaches of warranty. The court said that those who wish to merge the two “ignore the important conceptual differences between contract and tort that justify resisting their merger.” *ULGT*, 199 P.3d at 955.

We conclude that for purposes of a tort claim for breach of the implied warranty of merchantability, Utah law provides that the warranty is breached only if the plaintiff establishes the elements of a strict-products-liability claim for defective manufacture, defective design, or failure to warn. *See Grundberg v. Upjohn Co.*, 813 P.2d 89, 92 (Utah 1991) (“There are three types of product defects: manufacturing flaws, design defects, and inadequate warnings regarding use.”). This view has authoritative support outside of Utah. The Restatement (Third) of Torts: Products Liability § 2 comment n (1998) explains:

This Restatement contemplates that a well-coordinated body of law governing liability for harm to persons or property arising out of the sale of defective products requires a consistent definition of defect, and that the definition properly should come from tort law, whether the claim carries a tort label or one of implied warranty of merchantability.

*Accord Evans v. Lorillard Tobacco Co.*, 990 N.E.2d 997, 1010 (Mass. 2013) (claim for breach of implied warranty of merchantability requires proof of elements of product-defect claim); *Wright v. Brooke Grp. Ltd.*, 652 N.W.2d 159, 181–82 (Iowa 2002); *Freeman v. Hoffman-La Roche, Inc.*, 618 N.W.2d 827, 843–44 (Neb. 2000); *Hyundai Motor Co. v. Rodriguez ex rel. Rodriguez*, 995 S.W.2d 661, 665–67 & n.20 (Tex. 1999); *see also Gumbs v. Int’l Harvester, Inc.*, 718 F.2d 88, 94–95 (3d Cir. 1983) (collecting cases for the proposition that implied-warranty and strict-products-liability claims “are essentially the same,” *id.* at 94); Dan B. Dobbs et al., *Dobbs’ Law of Torts* § 448 (2d ed. 2015) (“As some authorities have observed, the standards for determining merchantability under warranty law and the standard for determining whether a product is defective in the law of strict tort liability are largely interchangeable.”).

Because Kirkbride’s implied-warranty claim gives him no additional ground for affirming the judgment below, we also reverse on that claim.

### **III. CONCLUSION**

We REVERSE the district court’s judgment and REMAND for further proceedings in accordance with this opinion.